



# TH

## 5,5.24



CONSTRUCTION



LOGISTICS



MINING &  
QUARRYING

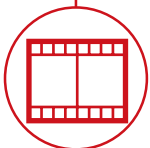

EVENTS AND  
FILM

TH  
5,5.24



**CAB**

Best-in-class  
safety and visibility



**PERFORMANCE**

Unrivalled lifting  
performance



**LOAD LIVE DIAGRAM**

Two real-time dynamic  
load charts

# TH

## 5,5.24

### DIMENSIONS (mm)

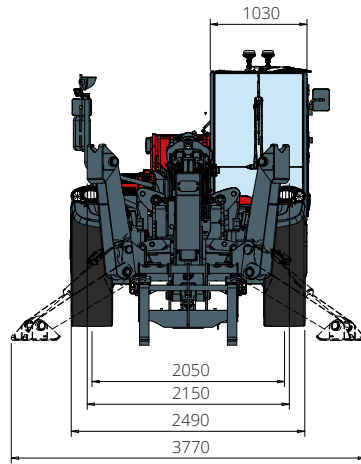

**FRONT**  
view

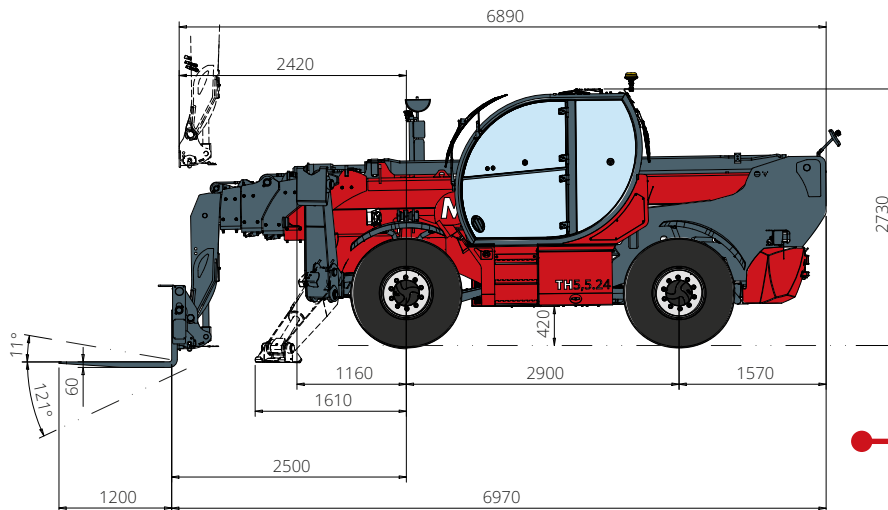

**SIDE**  
view

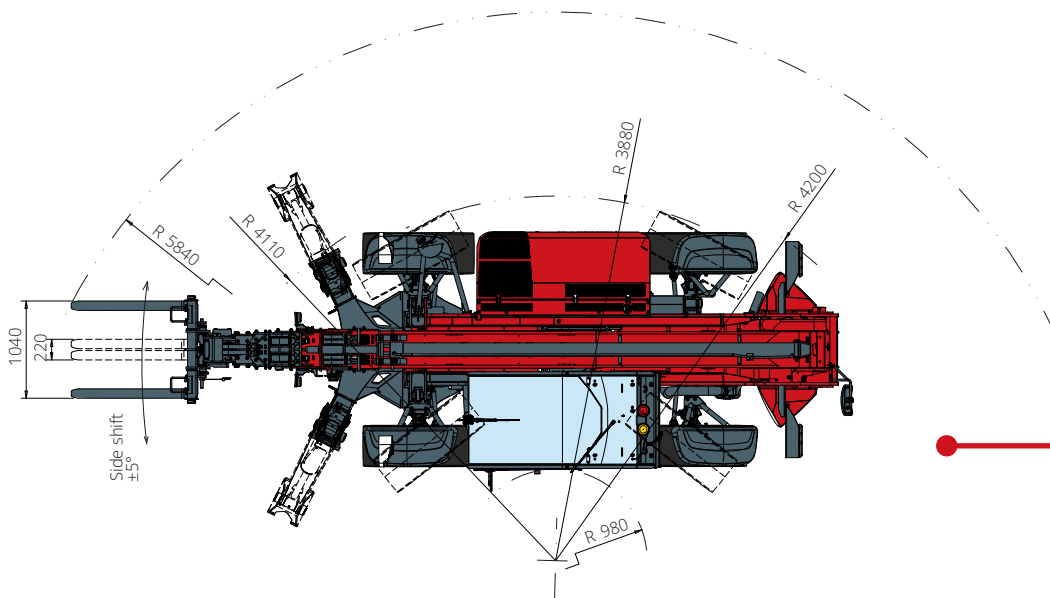

**TOP**  
view

Load chart with  
**FULLY EXTENDED STABILISERS**

ATT-03-040

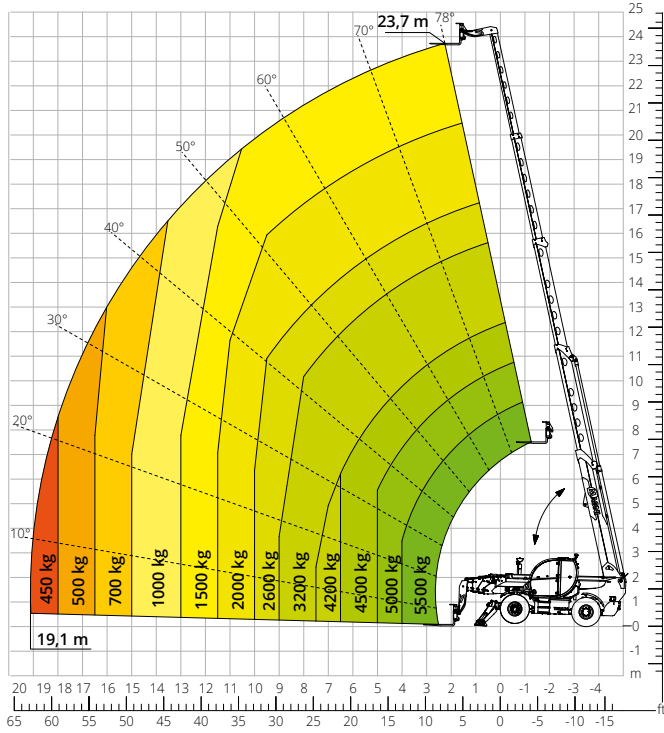

Load chart with  
**72x72 OVERSIZED FORK CARRIAGE**

ATT-03-048

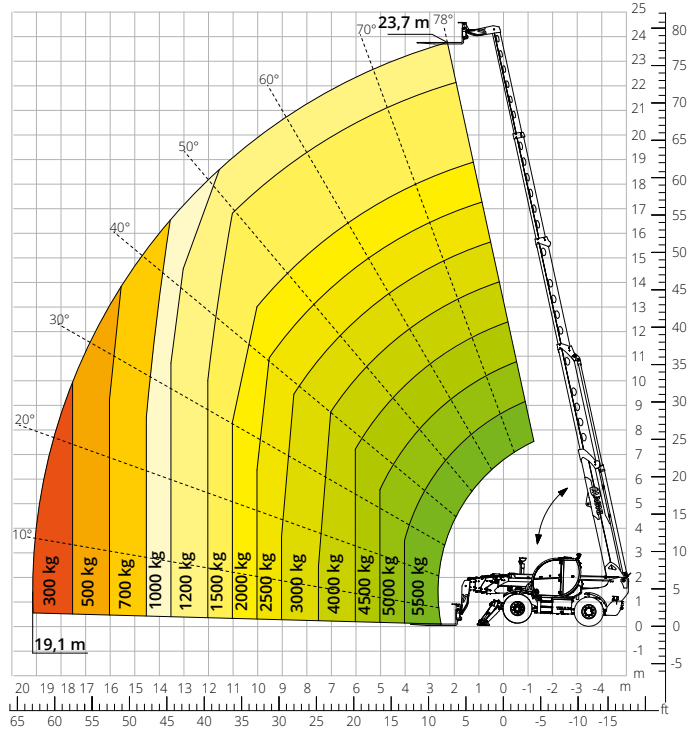

Load chart  
**72x72 OVERSIZED FORK CARRIAGE ON TYRES**

ATT-03-048

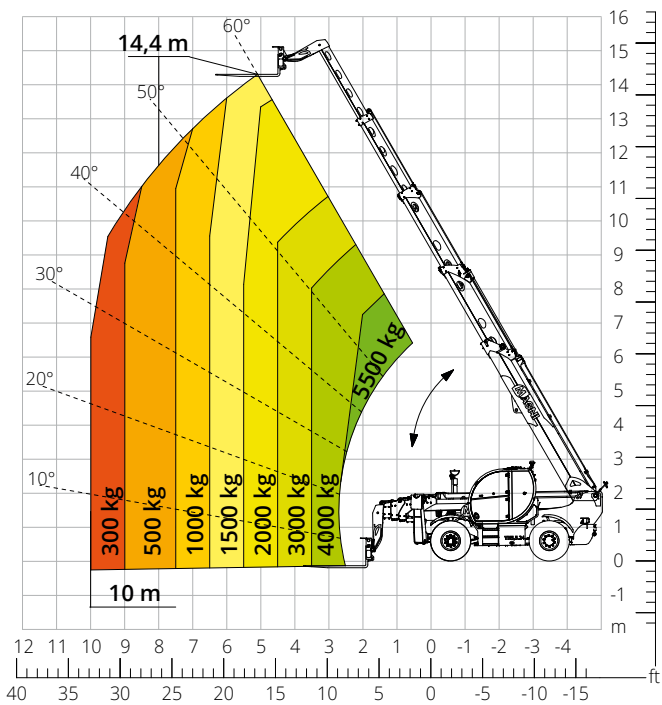

Load chart with  
**FORKS AND LOCKED AXLE (USA ONLY)**

ATT-03-040

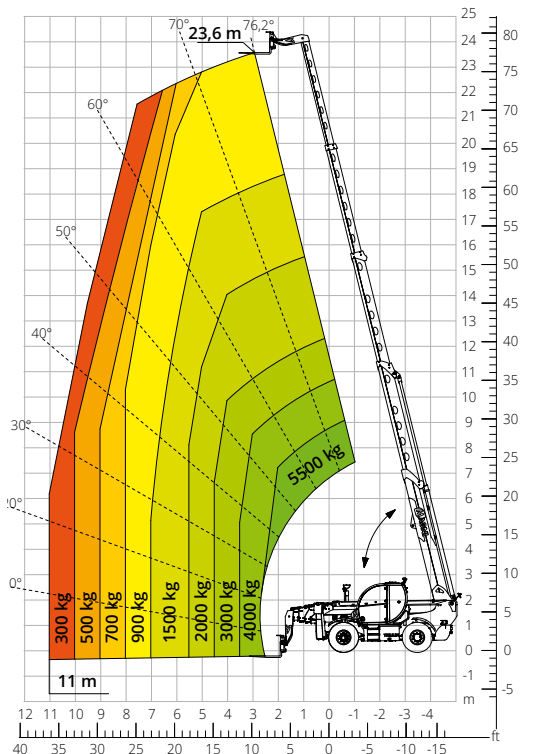

Load chart with  
**FORKS AND OSCILLATING AXLE**

ATT-03-040

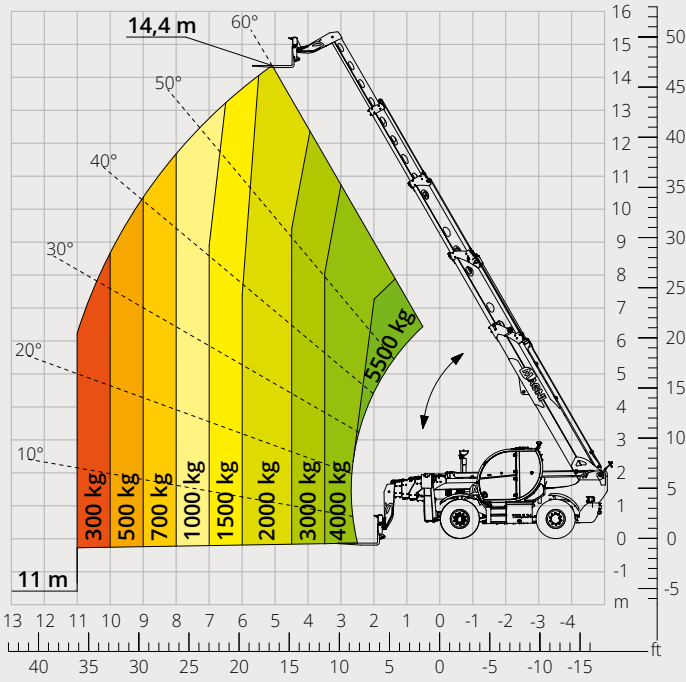

Load chart with  
**HOOK, 6,000 kg**

ATT-05-001

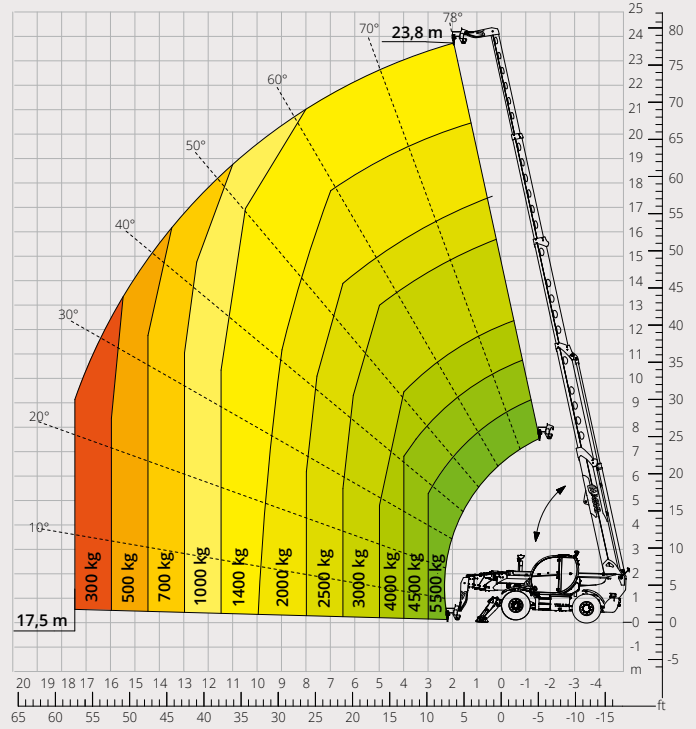

Load chart with  
**JIB, 2,000 kg**

ATT-04-013

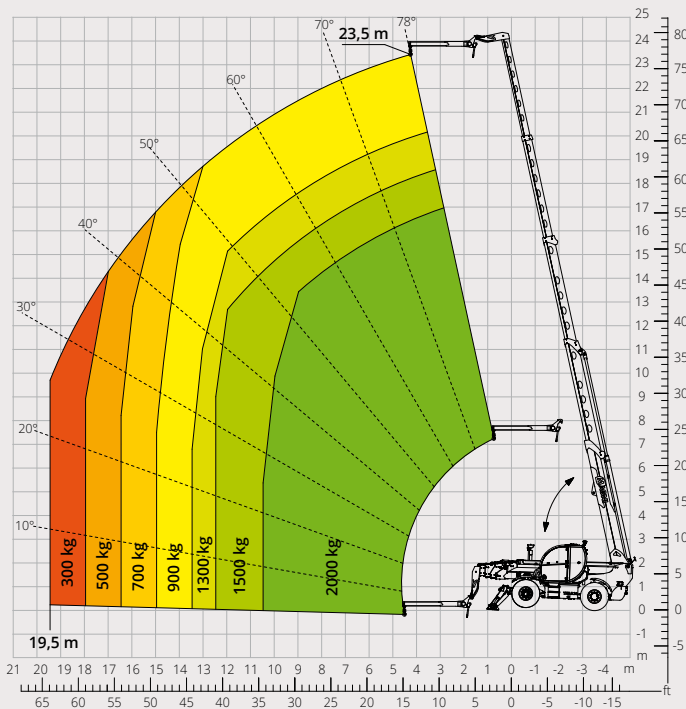



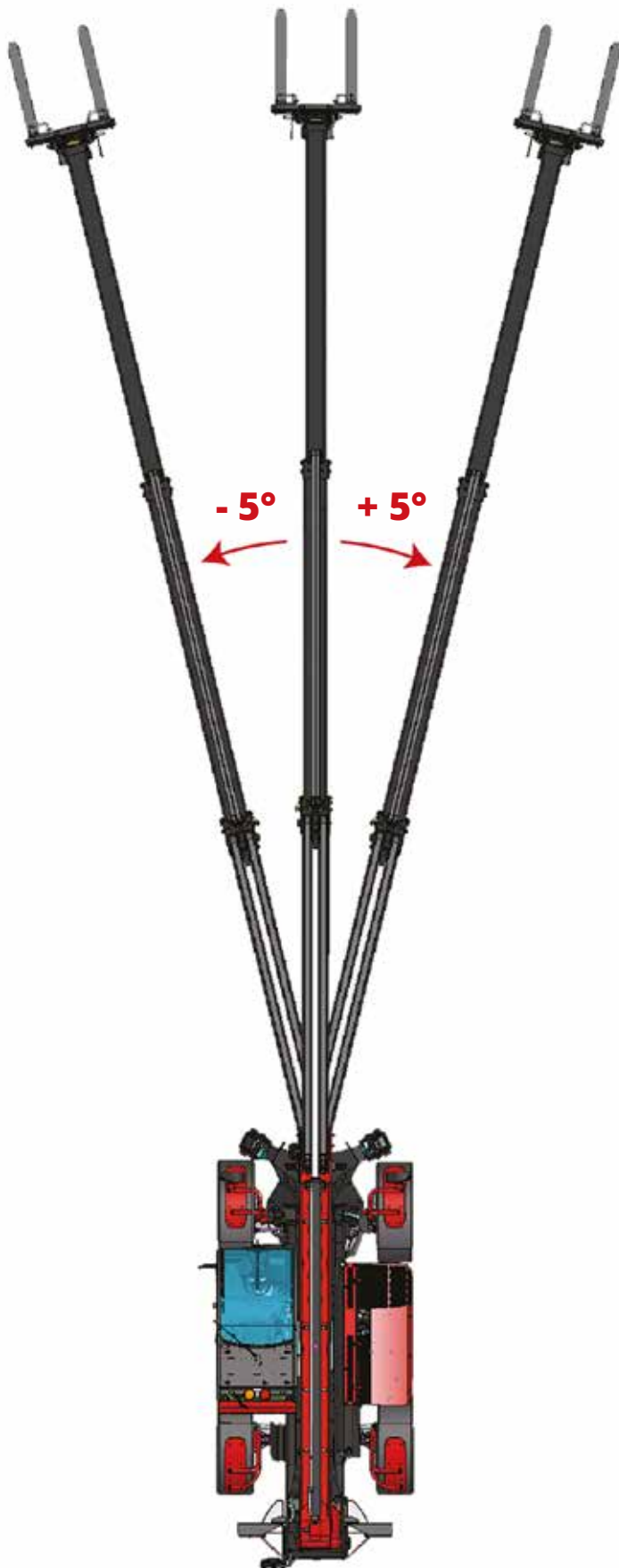

## LATERAL SHIFTING SYSTEM

This telehandler is equipped with a lateral shifting system that permits to move sideways the rear part of the chassis and, with it, the telescopic boom relative to the longitudinal axis of the machine to correct the load position without the need to move the machine.

This system, in fact, allow a shifting of  $\pm 5^\circ$  that corresponds to a shift of  $\pm 1,5$  m with the boom completely extended, independently from which attachment is equipped.

<b>Machine model</b>	Telescopic handler	TH 5,5.24	
	Maximum lifting capacity	5,500 kg	
	Maximum lifting height	23.70 m	
	Maximum reach	19.10 m	
<b>Stabilizer</b>	Type	Pivoting	
<b>Engine</b>	Model	<b>Deutz TCD 3,6 L4 EDG - Stage IIIA</b>	<b>Deutz TCD 3,6 L4 Stage V</b>
	Rated power	100 kW (136 hp) at 2,200 rpm	
	Maximum torque	500 Nm at 1,600 rpm	
	Displacement	3,6 l	
	Cylinders	4 in line	
	Engine configuration	Turbocharged direct injection diesel	
	Cooling system	Water – intercooler	
<b>Transmission</b>	Type	Hydrostatic	
	Maximum pressure	500 bar	
	Gear box	Dropbox, 2 speeds forward-reverse	
<b>Axles and brakes</b>	Type	Axles with planetary gearboxes	
	Front axle	Oscillating and steering with levelling, +/-8°	
	Rear axle	Oscillating and steering with hydraulic lock	
	No. of driving/steering wheels	4WD - 4WS	
	Steering mode	Frontal/Concentric/Crab	
	Service brake	Wet multi-disk on front and rear axle	
	Parking brake	Hydraulic with negative action on front axle	
<b>Performance</b>	Tyres dimensions	445/65 R22.5	
	Max. travel speed	40 km/h	
	Maximum mass towable on hook	3,100 kg	
	Gradeability	32%	
	Turning radius (end of forks)	5,840 mm	
<b>Weights</b>	Total unladen*	16,100 kg	
	Front axle unladen (boom retracted and lowered)*	6,700 kg	
	Rear axle unladen (boom retracted and lowered)*	9,400 kg	
<b>Tank and system capacities</b>	Fuel tank	150 l	
	AdBlue	10 l	
	Hydraulic oil tank	93 l	
	Engine oil tank	9 l	
<b>Hydraulic circuit for movements</b>	Cooling liquid	20 l	
	Circuit type	Load sensing	
	Service pump	Variable displacement	
	Max. hydraulic flow rate	105 l/min	
	Max. boom head flow rate	75 l/min	
	Max. operating system pressure	350 bar	
	Controls for boom movements	SIL 2 electro-proportional valve	
Movements control	1 joystick with integrated manoeuvre enable		
<b>Standard met</b>	2006/42/EC: EU Machinery Directive		
	2016/1628: EU Regulation on the emissions of stage V engines		
	EN 1459-X: Relating to standards on the safety requirements for variable reach machines		
	EN 280/EN 280-1/EN 280-2: standards relating to mobile elevating work platforms (if available)		
ROPS/level 2 FOPS: relating to the standards for protective structures			

*The data given in this brochure are provided for information purposes and are subject to change without prior notice.*

*All images are purely guideline and might not give an exact representation of the product.*

*\*the stated weight refers to the vehicle unladen with standard equipment and may vary depending on the chosen configuration.*

The standard machine configuration includes:

## CAB

- Comfort seat with adjustable headrest
- Adjustable steering column
- Analogue joypad
- Adjustable sunblind
- Heating
- Air conditioning
- FM/AM radio with USB and Bluetooth connectivity
- Ambient LED lights
- USB Type-A and Type-C (5 V) inputs

## REAL TIME INFORMATION

- Touchscreen, 7"
- MCTS – Magni Combi Touch System on-board software
- Automatic RFID tools recognition system
- LMI – Load Moment Indicator
- LLD – Live Load Diagram
- Onboard and remote integrated diagnostics

## TECHNICAL SPECIFICATIONS

- Q-Fit standard
- Provision for platform
- Advanced three-line CAN BUS system
- Automatic levelling system for outriggers
- Automatic front and rear wheel alignment
- Chassis sideshift system
- Automatic parking brake
- Mechanical battery cut-off in engine compartment
- Electrical system: 24 V – IP67

## SERVICE

Warranty: 24 months/2,000 hours